



## Multiple I/O

HDMI/USB/LAN/COM

## Robust Chassis

corrosion and oxidation resistance

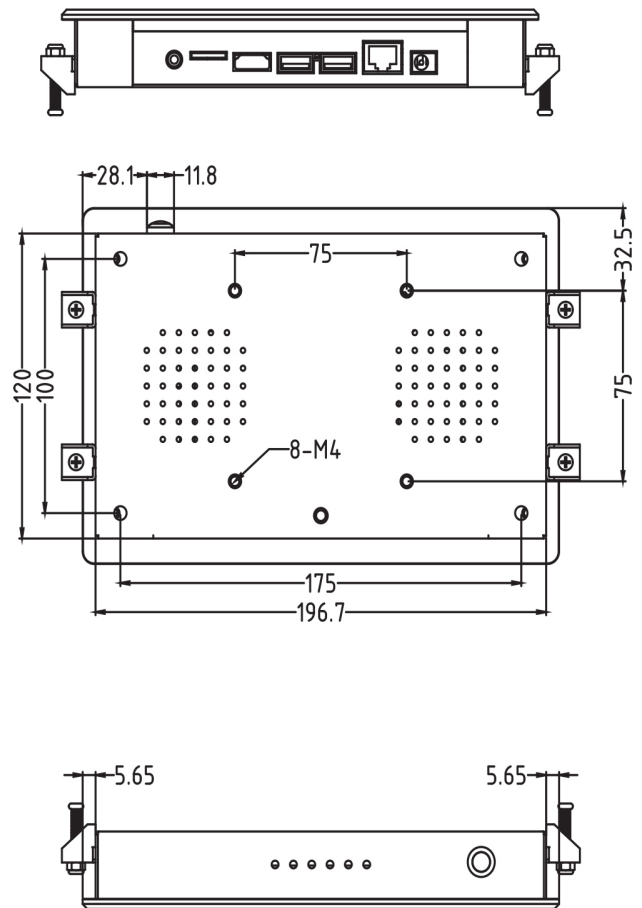
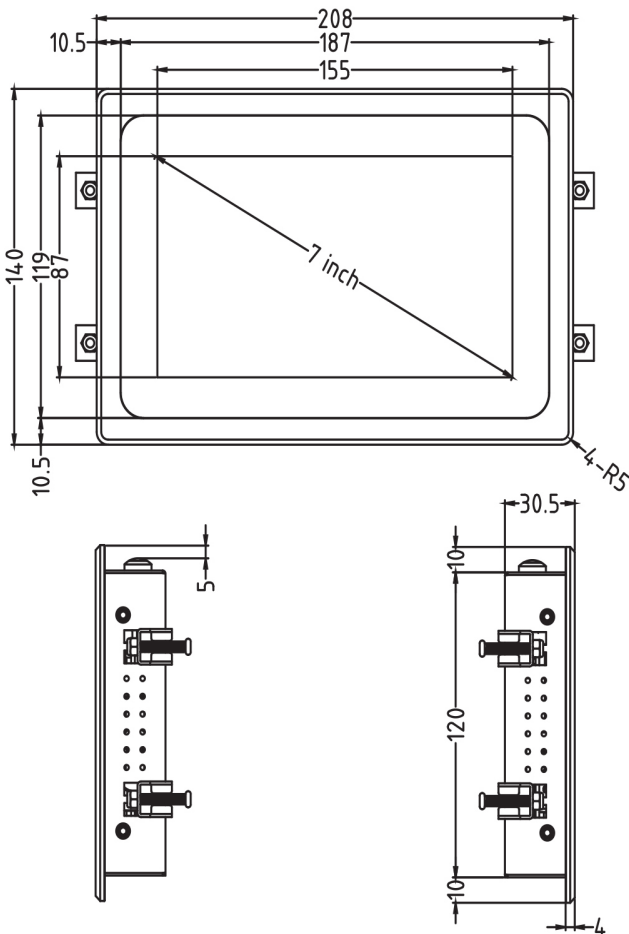

## PC System

CPU	Rockchip RK3568	Rockchip RK3128	Rockchip RK3399
Graphic GPU	ARM G52 2EE	ARM® Mali-400 MP2	PowerVR G6110
Audio	-	-	-
Memory	2G (4G optional)	1G	2G (4G optional)
Storage	16G/32G eMMC	8G eMMC	16G/32G eMMC
Network	10/100M RJ45, 802.11a/b/g/n Wifi	10/100M RJ45, 802.11a/b/g/n Wifi	10/100M RJ45, 802.11a/b/g/n Wifi
Pre-installed	Android 11	Android 7.1	Android 9

## LCD Panel

IP Rating	IP65 Front
Screen diagonal	7inch
Active screen size (mm)	155.5W* 87.5H
Aspect ratio	16:9
Physical resolution	1024*600
Colours displayed	16.7M , 50% (CIE1931)
Brightness (cd/m2)	250
Contrast	1000:1
Visual Angle H/V (°)	175/175
Backlight Lifetime (hours)	LED / 15,000

## Power

Power Supply	100-240V AC;
Working Power (V)	24
Power Consumption (W)	<25
Stand-By Consumption (W)	<0.5

## External Connectors

15-40v DC IN	x1	HDMI out	x1
OTG USB	x1	USB	X1
RJ45 Ports	x1	Tf card slot	x1
Headphone	x1	DB9 (TTL)	optional

## Installation

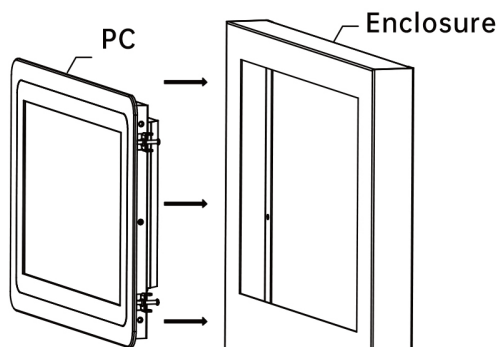

Step 1: Settle the PC from outside to inside of the enclosure.

## Operation

Operating Temperature (°C)	0°C-50°C
Humidity Range (RH)	10% - 80%
Net weight (kg)	0.876KG
Gross weight (kg)	1.35kg
Housing material	Sheet Metal
Housing (mm) L × W × H	208*140*30.5
Mounting	75*75

## Touch Panel

Touch Technology	Projected Capacitive
Touch Connector	USB
Surface Hardness	7

## Included in the

Manual	x1	Settling Snaps	X4
WIFI antenna	X1		

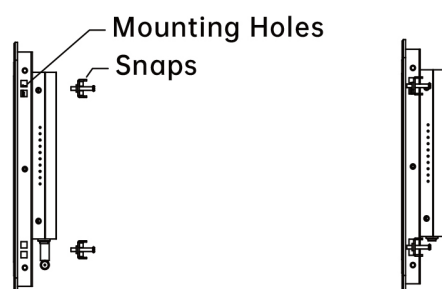

Step 2: Fix the snaps on the mouting holes of the PC ,and tighten the snaps with screwdriver.